

A Method for Generating Boundary-Orthogonal Curvilinear Coordinate Systems Using the Biharmonic Equation

PANAGIOTIS DEMETRIOU SPARIS

Polytechnic School of Xanthi, Democritus University of Thrace, Xanthi, Greece

Received January 5, 1984; revised January 3, 1985

The biharmonic equation transformed in the computational domain is solved for the generation of boundary-orthogonal curvilinear coordinate systems. The method permits direct and complete control of the mesh point location on the boundary as well as the angle of intersection of the coordinate lines with the boundary. The method may also be used for the generation of meshes in segmented fields. Finally, the method can be easily extended in three dimensions. © 1985 Academic Press, Inc.

INTRODUCTION

In the last decade, an extensive array of boundary-fitted coordinate system generation techniques have been developed for the solution of physical problems described by partial differential equations in domains with complicated boundaries. A very extensive review of these methods has been recently compiled by Thompson, Warsi, and Mastin in Ref. [1].

Since the generation of the boundary-fitted coordinate system has no physical meaning in relation to the problem considered, there is a freedom of choice on the coordinate system generation procedure.

The great majority of the coordinate system generation methods are based on partial differential equations involving the Laplace operator. These equations are usually solved using a coordinate transformation from the physical domain to an orthogonal computational domain. Using this approach, local refinement of the mesh can be achieved by introducing appropriate mesh control functions into the generating system of equations, or by giving nonzero values to the Laplacian of the curvilinear coordinates. This is the original approach pioneered by Thompson, Thames, and Mastin in Ref. [2], where the governing system is composed by two Poisson equations.

Special attention has been given to methods that would generate orthogonal curvilinear coordinate systems, due to the simplicity of the expression of the partial differential equations in these coordinate systems. Also, depending on the actual physical problem to be solved on the boundary-fitted coordinate system,

orthogonal systems may simplify considerably the application of the boundary conditions. The methods of orthogonal or or nearly orthogonal curvilinear coordinate system generation can be based on the solution of equations involving elliptic or hyperbolic operators (Ref. [1]). The nature of these operators indicates that elliptic operators should be more appropriate for closed domains, whereas hyperbolic operators should be used for open domains as isolated bodies, etc. Another interesting approach is the use of parabolic operators as proposed by Nakamura in Ref. [3].

A basic problem that arises with the use of hyperbolic generating operators is the propagation of mesh nonuniformities originating from geometric singularities at the domain boundaries. Similar effects are not present with elliptic operator methods due to the diffusive nature of these equations. On the other hand, the most commonly used Laplace's operator demonstrates a lack of complete control of the mesh, due to the nature of the boundary conditions appropriate for the solution of second-order elliptic operators. It is well known that the appropriate boundary conditions for the Laplace or the Poisson equations are the definition of the function or its normal derivative, or a linear combination of both on the boundary, namely, the Dirichlet, the Neumann, and the mixed condition, respectively.

Generally, if one applies a Laplace operator-based coordinate system generation procedure, on the domain boundaries he may specify either the location of the mesh points, or the angle with which each family of coordinate lines will meet the boundary. In the case where an orthogonal system is desired, the angle of the coordinate lines on the boundary must be specified as 90° , and this condition deprives us, in principle, of the complete control of the mesh spacing. The general behavior of coordinate lines generated by the Laplace equation with Neumann boundary conditions is to concentrate near convex corners, and disperse near concave. To illustrate these effects the following field presented in Fig. 1 was examined. Fields with similar geometry are very common in two-dimensional cascade flows. In this case, the lines BC , GF describe the upper and lower surface of a blade considered as a flat plate for simplicity. An infinite series of these blades forms the 2-D cascade. To solve an inviscid flow problem in this domain, one has to apply periodic conditions on the segments AB , CD , HG , FE , the appropriate inlet and exit conditions on the segments AH , DE , and, finally, the condition $u_n = 0$ on the segments BC , GF , where u_n is the normal velocity component on the blade surface. The application of the periodic conditions on the segments AB , HG and CD , FE would be simplified if there is a one-to-one correspondence of the mesh points on these segments to avoid interpolation.

Similarly, the b.c. on the blade surfaces BC , GF could be simplified if the coordinate lines were normal to these segments. Three curvilinear coordinate systems were generated by solving the transformed Laplace equation in the orthogonal domain $A'B'C'D'E'FG'H'$ with appropriate b.c., following the method introduced by Thompson, Thames, and Mastin in Ref. [2]. In the first case, Dirichlet conditions are applied on AB , BC , CD , HG , GF , FE , and the resulting coordinate system is presented in Fig. 2. In the second case presented in Fig. 3, Neumann con-

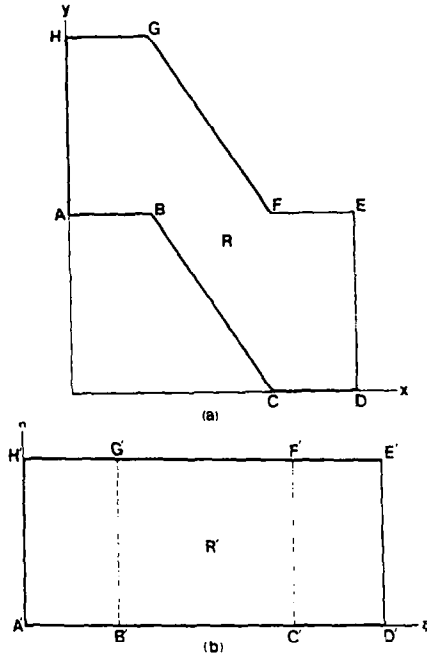

FIG. 1. A 2-D cascade. (a) Physical domain. (b) Transformed domain.

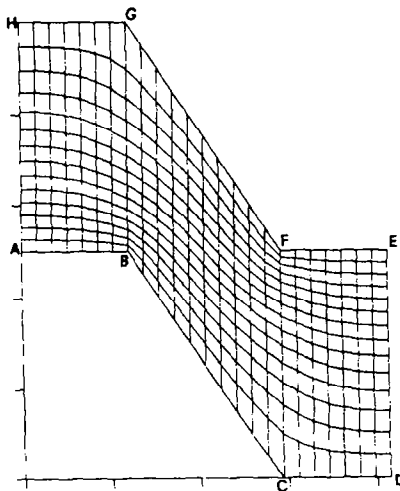

FIG. 2. The curvilinear system generated by the Laplace equation with Dirichlet conditions on AB, BC, CD, HG, GF, FE and Neumann conditions on AH, DE for the 2-D cascade.

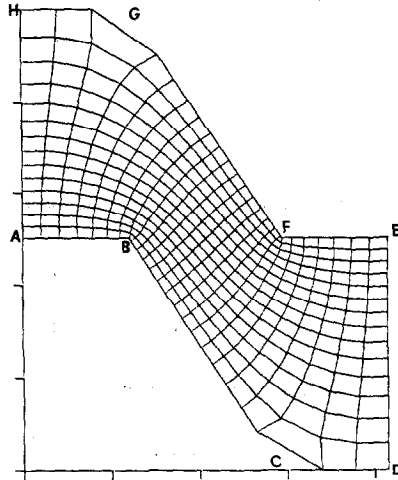

FIG. 3. The orthogonal system generated by the Laplace equation with Neumann conditions on all boundaries for the 2-D cascade.

ditions are applied on these segments. Finally, in the third case presented in Fig. 4, Dirichlet conditions are applied on AB , CD , HG , FE and Neumann conditions on BC , GF .

In all three cases, Neumann conditions are applied on the segments AH , DE . From these illustrations it is clear that the mesh of Fig. 2 is appropriate for the application of the symmetry condition, but does not simplify the normal velocity condition on BC , GF . Reverse results are obtained with the Neumann condition as indicated in Fig. 3 yet the mesh is orthogonal. Finally, the mesh presented in Fig. 4

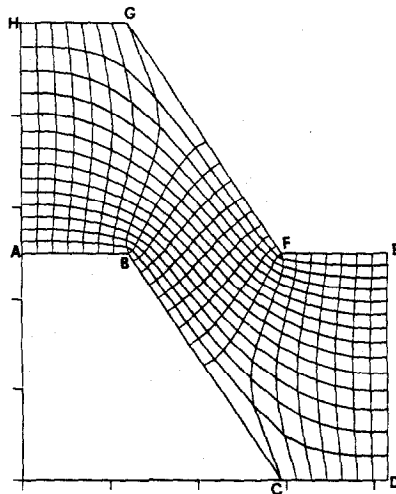

FIG. 4. The curvilinear system generated by the Laplace equation with Dirichlet conditions on AB , CD , HG , FE and Neumann conditions on AH , DE , BC , GF for the 2-D cascade.

is appropriate for the application of all the b.c., nevertheless, it is nonorthogonal. A common characteristic of all these Laplace-based meshes is the existence of large mesh density variations between the regions in the neighborhood of the corners B , F and C , G . To rectify the mesh distribution one has to abandon the simplicity of the Laplace equation and use one of the mesh stretching techniques of Ref. [1], for example, the solution of the Poisson equation with appropriate source terms. In this case, the generated curvilinear coordinate system will not be orthogonal in general. To accomplish a simultaneous control of the mesh density distribution and the angle of intersection of the coordinate lines with the boundaries one has to resort to more complicated methods, for example, the Sorenson and Steger method of Ref. [4]. The basic idea of this approach is to iteratively adjust the source term of the Poisson equation to control simultaneously the mesh density and the skewness at the boundary surfaces. In this way, we indirectly bypass the boundary condition limitations of second-order elliptic operators posed earlier. As we will demonstrate, this approach has a lot in common with the biharmonic mesh generation method presently proposed. The biharmonic operator $\nabla^2(\nabla^2)$ appears as a natural choice for a curvilinear coordinate system generation method, since it may be readily reduced to a combination of a Poisson and a Laplace equation for which the solution method in the transformed space is well developed. The higher order of the biharmonic operator allows the simultaneous application of the boundary conditions on both the function and its derivative. In this way, we may prescribe both the location of the mesh points and the angle of intersection of the coordinate lines with the boundary, generating a coordinate system that is orthogonal on the boundaries and has the desired mesh distribution.

The biharmonic equation is solved numerically either by the direct or by the coupled approach. In the first case a 13-point finite difference approximation is normally used as described by Gupta and Mahonar [5]. This approach applied in the case of a coordinate system generation would require the solution of the transformed biharmonic equation in the transformed domain ξ, η . On the contrary, the coupled approach basically splits the biharmonic equation

$$\Delta\Delta\varphi = 0$$

into two equations, namely,

$$\Delta\varphi = p, \quad \Delta p = 0,$$

that can be easily transformed and solved in the transformed domain of ξ, η , using the familiar Thompson method [2], requiring only minor modifications on previously existing codes based on the solution of the Laplace and Poisson equations. This simpler approach will be followed in the present paper. The splitting of the biharmonic equation into a Poisson and a Laplace equation demonstrates the similarity of the present method with the method of Ref. [4]. Here, the function $p = p(x, y)$ that satisfies the Laplace equation $\Delta p = 0$ plays the

role of the iteratively adjusted source term of the Poisson equation used as generating equation in Ref. [4]. From this discussion it is clear that the biharmonic equation allows a strict and direct control of the mesh density and skewness on the boundaries.

The biharmonic equation has also been used as a mesh generating equation by Bell, Shubin, and Stephens in Refs. [6, 7]. In this case, a system of biharmonic equations is solved in the computational domain for the physical coordinates x, y , namely,

$$\frac{\partial^4 x}{\partial \xi^4} + 2 \frac{\partial^4 x}{\partial \xi^2 \partial \eta^2} + \frac{\partial^4 x}{\partial \eta^4} = 0$$

and

$$\frac{\partial^4 y}{\partial \xi^4} + 2 \frac{\partial^4 y}{\partial \xi^2 \partial \eta^2} + \frac{\partial^4 y}{\partial \eta^4} = 0.$$

It should be noted that there is no extremum principle for this system of equations, and consequently, it is possible to lose the invertibility of the transformation from the transform to the physical domain.

The presently proposed approach is to solve the biharmonic equations

$$\frac{\partial^4 \xi}{\partial x^4} + 2 \frac{\partial^4 \xi}{\partial x^2 \partial y^2} + \frac{\partial^4 \xi}{\partial y^4} = 0$$

$$\frac{\partial^4 \eta}{\partial x^4} + 2 \frac{\partial^4 \eta}{\partial x^2 \partial y^2} + \frac{\partial^4 \eta}{\partial y^4} = 0$$

transformed in the computational domain ξ, η , and thereby retaining the desirable extremum principle that is necessary for the transformation inversion.

BIHARMONIC EQUATION

Consider the Dirichlet problem for the biharmonic equation

$$\Delta \Delta \varphi(x, y) = 0, \quad (x, y) \in R \quad (1)$$

$$\varphi(x, y) = f(x, y), \quad \frac{\partial \varphi}{\partial n}(x, y) = 0, \quad (x, y) \in C \quad (2)$$

where R is a closed domain in two dimensions and C is its boundary. The derivative $\partial/\partial n$ is taken in the outward normal direction on the boundary C .

The biharmonic equation may be split into the couple of equations

$$\Delta \varphi(x, y) = p(x, y), \quad (x, y) \in R \quad (3)$$

and

$$\Delta p(x, y) = 0, \quad (x, y) \in R. \quad (4)$$

The boundary values of φ , p should satisfy the conditions

$$\varphi(x, y) = f(x, y), \quad (x, y) \in C \quad (5)$$

and

$$p(x, y) = \Delta \varphi(x, y) - c \frac{\partial \varphi}{\partial n}(x, y), \quad (x, y) \in C \quad (6)$$

where c is an arbitrary nonzero constant (Ref. [8]).

To generate a curvilinear coordinate system by using the biharmonic equation, one has to solve the set of partial differential equations

$$\Delta \Delta \xi(x, y) = 0 \quad (7)$$

$$\Delta \Delta \eta(x, y) = 0. \quad (8)$$

Applying the coupled approach, this set can yield the system of equations

$$\Delta \xi(x, y) = p \quad (9)$$

$$\Delta p(x, y) = 0 \quad (10)$$

$$\Delta \eta(x, y) = q \quad (11)$$

$$\Delta q(x, y) = 0. \quad (12)$$

With the dependent and independent variables interchanged, Eqs. (9), (10), (11), (12) in the transformed plane become

$$\alpha x_{\xi\xi} - 2\beta x_{\xi\eta} + \gamma x_{\eta\eta} = -J^2(px_{\xi} + qx_{\eta}) \quad (13)$$

$$\alpha y_{\xi\xi} - 2\beta y_{\xi\eta} + \gamma y_{\eta\eta} = -J^2(py_{\xi} + qy_{\eta}) \quad (14)$$

where $\alpha = x_{\eta}^2 + y_{\eta}^2$, $\beta = x_{\xi}x_{\eta} + y_{\xi}y_{\eta}$, $\gamma = x_{\xi}^2 + y_{\xi}^2$, $J = x_{\xi}y_{\eta} - y_{\xi}x_{\eta}$, from the transform of Eqs. (9), (11), and

$$\alpha p_{\xi\xi} - 2\beta p_{\xi\eta} + \gamma p_{\eta\eta} = 0 \quad (15)$$

$$\alpha q_{\xi\xi} - 2\beta q_{\xi\eta} + \gamma q_{\eta\eta} = 0 \quad (16)$$

from the transformation of Eqs. (10), (12).

The boundary conditions for Eqs. (13), (14) are

$$x = x(\xi, \eta), \quad y = y(\xi, \eta) \quad \text{on } C', \text{ i.e., on } a'b'c'd'a'$$

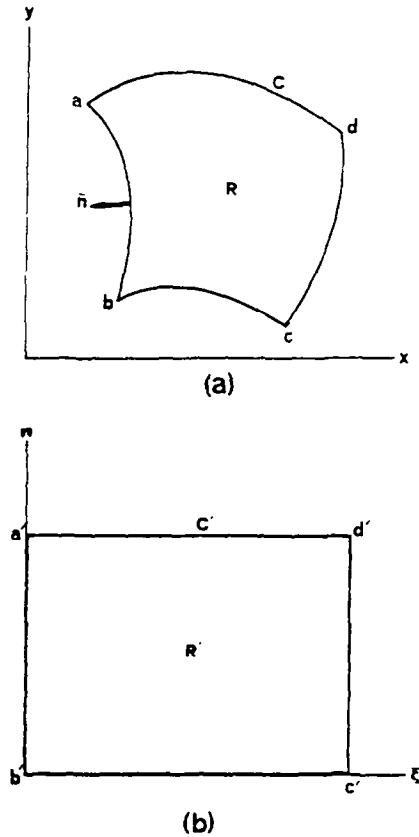

FIG. 5. A simply connected domain. (a) Physical domain. (b) Transformed domain.

as illustrated in Fig. 5, to generate a coordinate system that would have coordinate lines passing through given mesh points on the boundary C .

The boundary conditions for Eqs. (15), (16) are considerably more complex. If we solve Eqs. (13), (14) with respect to p , q we obtain

$$x_{\xi} p + x_{\eta} q = -\frac{1}{J^2} (\alpha x_{\xi\xi} - 2\beta x_{\xi\eta} + \gamma x_{\eta\eta}) = \mathcal{D}x$$

$$y_{\xi} p + y_{\eta} q = -\frac{1}{J^2} (\alpha y_{\xi\xi} - 2\beta y_{\xi\eta} + \gamma y_{\eta\eta}) = \mathcal{D}y$$

and finally

$$p = (y_{\eta} \mathcal{D}x - x_{\eta} \mathcal{D}y) / J \quad (17)$$

$$q = (x_{\xi} \mathcal{D}y - y_{\xi} \mathcal{D}x) / J. \quad (18)$$

However,

$$p = \Delta\xi, \quad q = \Delta\eta. \tag{19}$$

Therefore, for the boundary conditions of Eqs. (15), (16) we obtain according to Eq. (6)

$$p = \Delta\xi - c \frac{\partial \xi}{\partial n} \tag{20}$$

$$q = \Delta\eta - c \frac{\partial \eta}{\partial n} \quad \text{with } c \neq 0, \tag{21}$$

or using Eqs. (17), (18), (19),

$$p = (y_\eta \mathcal{L}x - x_\eta \mathcal{L}y)/J - c \frac{\partial \xi}{\partial n} \quad \text{on } b'c', a'd' \tag{22}$$

$$q = (x_\xi \mathcal{L}y - y_\xi \mathcal{L}x)/J - c \frac{\partial \eta}{\partial n} \quad \text{on } b'a', c'd'. \tag{23}$$

The effect of the arbitrary constant c on the orthogonality of the coordinate lines on the boundaries requires some additional clarification. In the interior of the domain p, q satisfy Eqs. (19), whereas at the boundary the conditions for p, q are posed by Eqs. (20), (21). As the computation approaches convergence, the values of p, q on the boundaries tend to the final values of $\Delta\xi, \Delta\eta$, respectively. Therefore, Eqs. (20), (21) tend to obtain the form

$$c \frac{\partial \xi}{\partial n} = 0 \quad \text{and} \quad c \frac{\partial \eta}{\partial n} = 0$$

i.e., the lines $\xi = \text{const}, \eta = \text{const}$ tend to become normal to the corresponding boundaries.

In the present computations the value of the arbitrary constant c was taken equal to 1 in Eqs. (22), (23) after a number of trials. Theoretically, any nonzero value of c is acceptable, however, from the numerical point of view, only values of $O(1)$ should be used. Actually, if a large value of c is used, the term $c(\partial\varphi/\partial n)$ in Eq. (6) would dominate over the term $\Delta\varphi(x, y)$. In this case on the boundary

$$p(x, y) \simeq c \frac{\partial \varphi}{\partial n}$$

violating strongly Eq. (3). Numerical experiments with a value $c = 10$ fail to converge. On the other hand, computations using the value $c = 2$ converged to the same mesh as with $c = 1$.

The application of the boundary conditions (22), (23) for p, q presents the problem that the evaluation of some of the derivatives on the boundaries using centered differences would require the use of dummy points. A plausible procedure estimating $\Delta\xi, \Delta\eta$ is to use the interior points, as proposed by Ehrlich and Gupta in Ref. [9]. This procedure may give first- or second-order accuracy, depending on the number of interior points used in the interpolation formulae.

In the present computation, this approach was considered complicated, and instead of computing $\Delta\xi, \Delta\eta$ on the boundary, the Laplacians of ξ, η were evaluated at the next interior row of mesh points, and the values obtained were used on the boundary. This rough estimate worked very well, and no stability or convergence problems were noted.

The system of Eqs. (13), (14), (15), (16) may be solved by SOR iteration, starting from an initial arbitrary mesh generated by interpolation between the known boundary point coordinates. Using the initial values of x, y , the initial values of p, q can be computed at the interior points by the application of Eqs. (17), (18). On the boundary points, the values of p, q are computed using Eqs. (22), (23) with $\Delta\xi, \Delta\eta$ estimated on the next row of points at the interior of the domain. The initial values of x, y, p, q are then introduced in Eqs. (13), (14), (15), (16) to generate improved values of x, y, p, q . This procedure can be repeated until a satisfactory degree of convergence is achieved. To simplify the solution of Eqs. (13), (14), (15), (16), one may omit the mixed derivative terms $x_{\xi\eta}, y_{\xi\eta}, p_{\xi\eta}, q_{\xi\eta}$, since the coefficient $\beta = x_{\xi}x_{\eta} + y_{\xi}y_{\eta}$ is zero for an orthogonal mesh. The coordinate systems generated by the biharmonic equation are not generally orthogonal, however, in all cases tested there was no noticeable alteration of the mesh caused by this omission.

The biharmonic equation allows in general an arbitrary distribution of mesh points on the domain boundaries. Since any solution of the Laplace equation satisfies the biharmonic equation as well, it is possible that, given an appropriate domain and mesh distribution on the boundaries, the resulting curvilinear coordinate system by the biharmonic approach will be orthogonal not only on the boundary lines, but also at the interior of the field. Similar effects are presently under investigation.

Another effect that is related to the mesh distribution on the boundaries is the dependence of the mesh skewness on the mesh density distribution. This interrelation is evident in Eqs. (20), (21), which relate the mesh distribution in the form of $\Delta\xi, \Delta\eta$, with the normal derivatives $\partial\xi/\partial\eta, \partial\eta/\partial\xi$, on the boundaries. In all cases tested, if the mesh density distribution was smooth on the boundaries, the resulting coordinate system has been orthogonal to the domain boundaries. However, if the mesh distribution exhibits strong nonuniformities, then the skewness of the mesh is affected in the neighborhood of these singularities, resulting in a locally nonorthogonal mesh on the domain boundaries. This effect will be examined further in the next section.

COMPUTER CODE AND APPLICATIONS

For the application of the present method to generate boundary-orthogonal curvilinear coordinate systems, a computer program has been compiled in BASIC to be used in both computers and minicomputers. This choice was dictated by the fact that presently minicomputers are used extensively for the solution of engineering and design problems. The BASIC language used in these units is enhanced with powerful graphic commands that may simplify considerably the task of plot generation on a CRT display or a plotter. This feature is very useful in the case of coordinate system generation. The main disadvantage of minicomputers, their limited computational speed, is usually outweighed by their minimal cost of CPU time, the ease of operation, and their availability.

In the present examples the computation has been carried out on a desktop computer HP-87XM connected to an HP-7225A plotter. Typical runs required several hours of CPU time for convergence. The same computation performed on a full-scale computer would require considerably less CPU time by several orders of magnitude.

In general, the biharmonic equation converges less rapidly than the Laplace or the Poisson equation. Comparative studies indicated that the proposed biharmonic method has roughly more than twice the CPU time requirements of the original Thompson, Thames, and Mastin procedure solving the Poisson equation.

The code was used for the generation of boundary-orthogonal curvilinear systems in a number of domains of engineering interest.

1. Cutting Tool Wedge

Figure 6 presents the curvilinear coordinate system generated by the biharmonic equation in the case of a trapezoid wedge to be used in connection with a stress analysis problem.

In this coordinate system, the lines $\xi = \text{const}$ are normal to the boundary segments AB , DC and pass through given points. Similarly the lines $\eta = \text{const}$ are

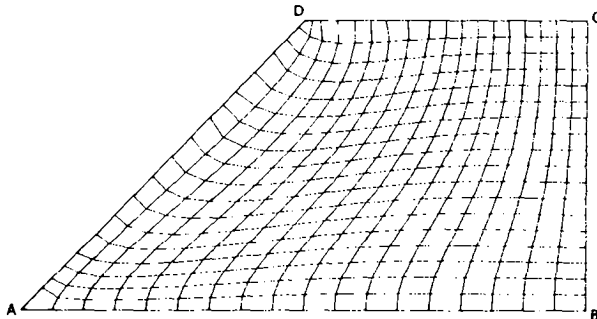

FIG. 6. A boundary-orthogonal coordinate system for a wedge generated by the biharmonic equation.

normal to the segments AD , BC and pass through given points. The mesh point distribution on AB , BC has uniform density. On these segments, the corresponding coordinate lines are normal with a high degree of accuracy, with the notable exception of the neighborhood of point A , where the orthogonality of the mesh is not well resolved due to the effect of the acute angle at A . Similar problems are not present at B , C , where the corresponding boundaries intersect at a right angle.

On the segments AD , DC , the mesh distribution is nonuniform. As a result of these nonuniformities, the corresponding coordinate lines exhibit small deviations from the normal direction.

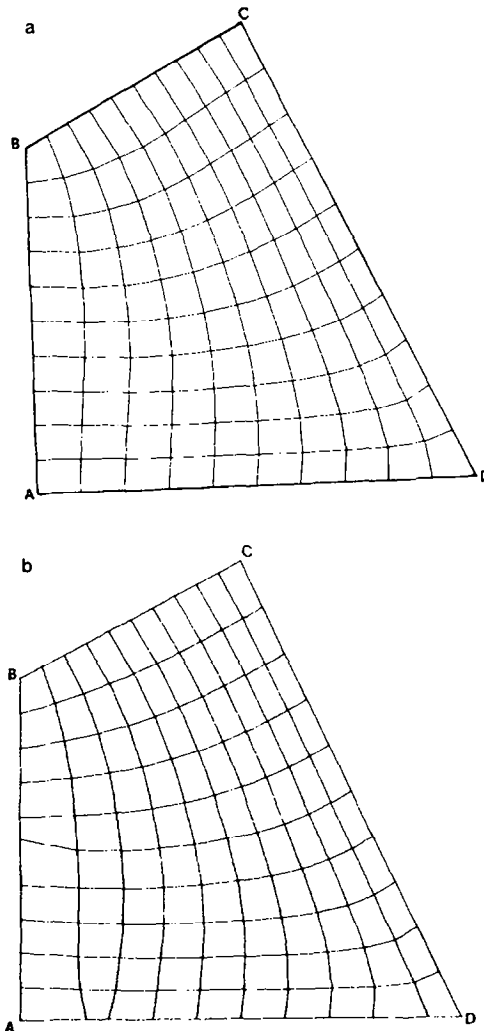

FIG. 7. A boundary-orthogonal coordinate system for a quadrilateral. (a) Uniform boundary mesh density. (b) Nonuniform boundary mesh density.

To illustrate further these effects, the following model problem was examined. In the quadrilateral domain $ABCD$ of Fig. 7, two coordinate systems have been generated with a uniform (Fig. 7a) and with a nonuniform (Fig. 7b) boundary mesh point distribution. From these results it is clear that due to the coupling of the orthogonality condition with the mesh point distribution caused by the application of the boundary conditions (20), (21), the direction of the coordinate lines deviates from the normal at boundaries where there are strong mesh point nonuniformities, namely, on AB , AD . These effects are not caused by a certain lack of convergence. The corresponding meshes have converged to within plotter pen thickness, with an error $e < 10^{-4}$.

2. A 2-D Cascade

In Fig. 8, a boundary-orthogonal curvilinear coordinate system is generated by the biharmonic approach for a 2-D cascade. Comparing this coordinate system with the coordinate systems generated by the solution of Laplace equation, illustrated in Figs. 2, 3, and 4, we observe that the greater control over the coordinate lines afforded by the biharmonic equation has formed a mesh more suitable for the application of the boundary conditions on the blade surfaces BC , GF and on the symmetry lines AB , CD , HG , FE . This mesh also presents a greater degree of uniformity, compared to the grids in Figs. 3 and 4. Small truncation errors on the description of the blade surfaces BC , GF do not seriously affect the smoothness of the mesh. On the other hand, the presence of abrupt mesh density variations on AH , ED create small deviations of the coordinate lines from the normal direction.

3. A Generator Pole

In Fig. 9, the curvilinear coordinate system generated by the biharmonic equation for a generator pole is presented. This mesh has been used for the solution of a heat transfer problem. The application of the boundary conditions for the heat equation

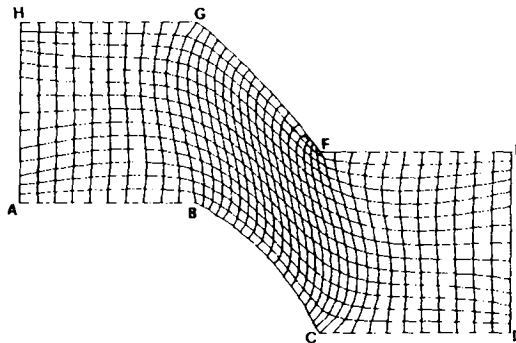

FIG. 8. A boundary-orthogonal coordinate system for a 2-D cascade generated by the biharmonic equation.

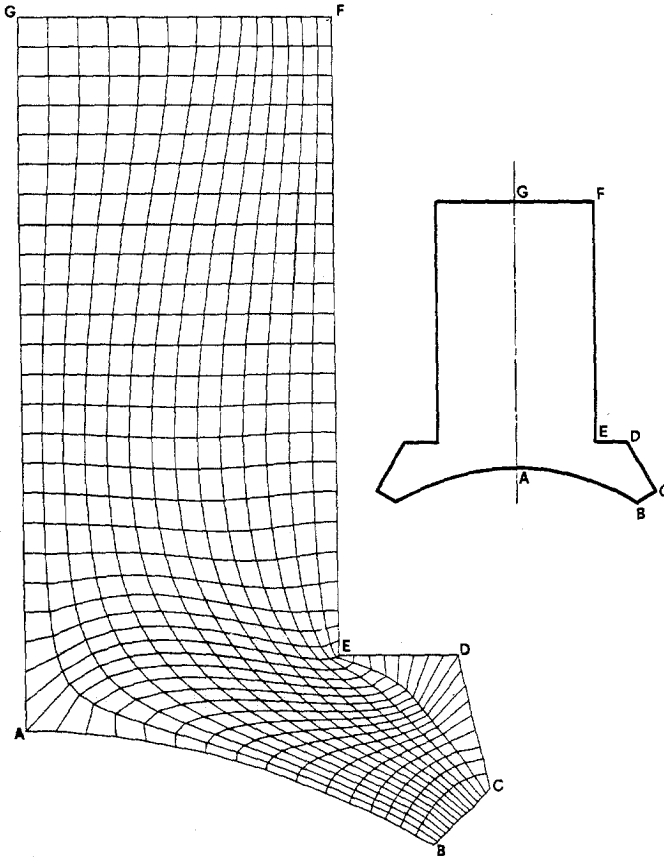

FIG. 9. A boundary-orthogonal coordinate system for a generator pole generated by the biharmonic equation.

on the surfaces where heat transfer takes place can be simplified with the use of a boundary-orthogonal mesh. In this case, the coordinate system is generated only for the right half of the pole section due to the symmetry.

4. *Metal-Clad Cables*

In Fig. 10 the boundary-orthogonal coordinate system in the interior of the metal-clad high-tension cable is presented. This coordinate system is used for the solution of the electrostatic field within the cable. In this case due to the symmetry of the field, the coordinate system needs to cover only one-sixth of the domain.

5. *Stress Concentration Specimen*

The proposed method for boundary-orthogonal curvilinear coordinate system generation using the biharmonic equation may be easily applied also in the case of

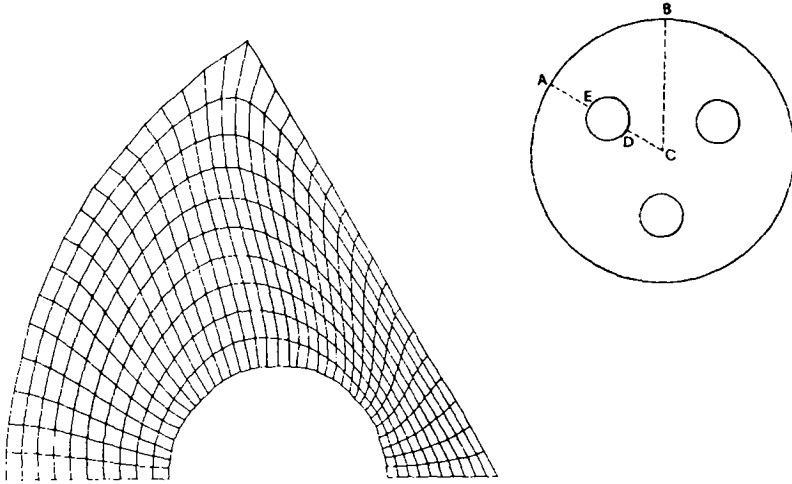

FIG. 10. A boundary-orthogonal coordinate system for a metal-clad cable generated by the biharmonic equation.

multiconnected domains. In this case, as presented in Fig. 11, the domain may be "unfolded" using the cut $C_3 \equiv C_4$. To illustrate the use of the biharmonic for multiconnected domains, the field presented in Fig. 12a was examined.

This curvilinear coordinate system will be used for the analysis of the stress concentration caused by the presence of the hole in the tension specimen. To unfold the domain, the cut $AH \equiv FG$ was considered. This cut is an artificial boundary of the domain, and the values of x, y, p, q must be computed with the same code as any other interior point of the field.

The specific coordinate system generated by the present method, illustrated in Fig. 12a, exhibits a somewhat confusing spiral effect. This effect is a result of the particular mesh point distribution on the boundaries that poses strict control over the coordinate lines. Thus, for example, the points I, K must be connected with a coordinate line normal to the circle and to the boundary CD .

To reduce the extent of similar distortions, one may choose a more symmetric mesh point distribution on the boundaries that would take into account partial symmetries existing in an asymmetric domain.

In the present example, if one arranges the mesh points on the exterior boundary $ABCDEF$ so that point K lies on the direction AHI , then the resulting mesh would be more appealing (Fig. 12b).

We should also point out that, although the number of grid points are reduced from 51×11 to 46×11 , the coordinate lines deviate less from the normal direction on the boundary $ABCDEF$ in the case of the pseudosymmetric mesh.

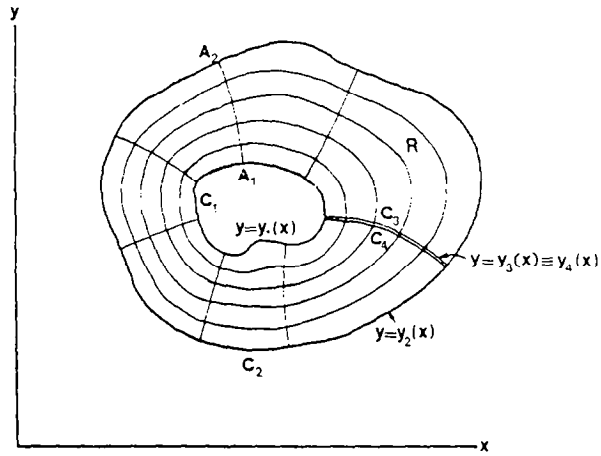

(a)

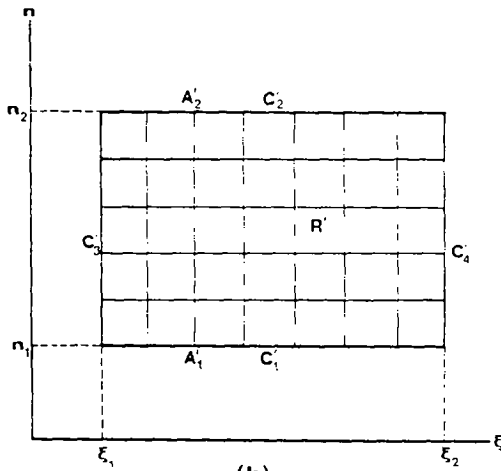

(b)

FIG. 11. A multiconnected domain. (a) Physical domain. (b) Transformed domain.

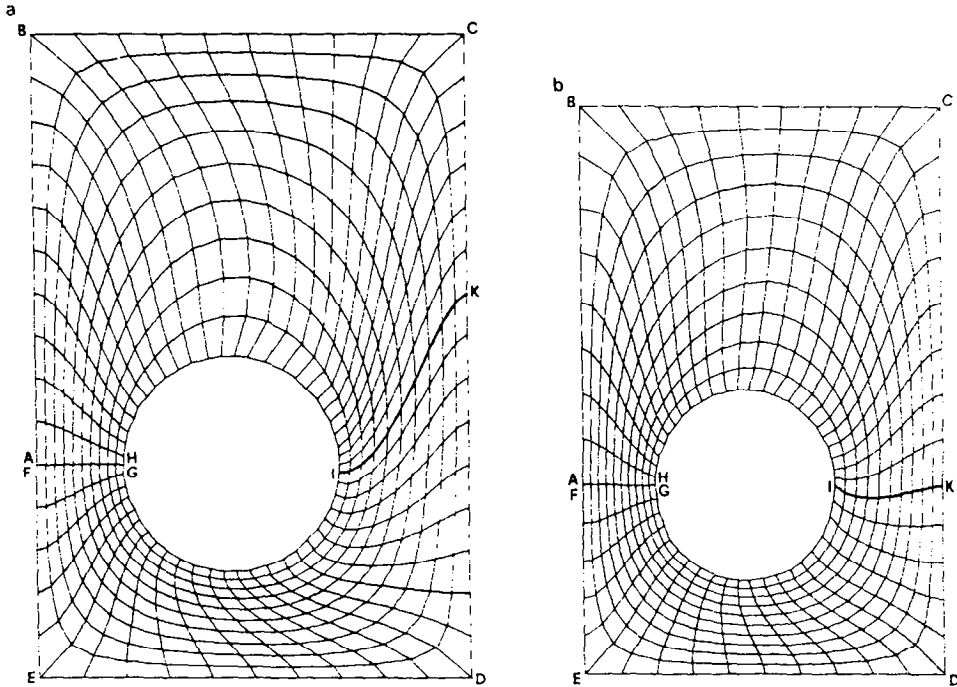

FIG. 12. A boundary-orthogonal coordinate system for a bored tension specimen generated by the biharmonic equation. (a) Uniform boundary mesh density. (b) Pseudosymmetric mesh.

CONCLUSIONS

The present paper presents a new method of boundary-fitted curvilinear coordinate system generation. This method uses the biharmonic operator to generate a coordinate system with a prescribed mesh point distribution on the domain boundary. This coordinate system has coordinate lines that are normal to the domain boundary. This boundary-orthogonal coordinate system generally simplifies the application of boundary conditions expressed in the normal direction to the field boundary. The solution of the biharmonic equation is accomplished by the coupled approach that splits the problem into the solution of a Poisson and a Laplace equation. The solution of these equations is carried out in the transformed domain in a similar manner with the well-established methods of boundary-fitted coordinate system generation based on the Laplace operator, and thus retains the extremum principle. The proposed method may be used for coordinate system generation in simple- or multiple-connected regions in two or three dimensions. Three-dimensional coordinate system generation codes are presently under development at the Democritus University of Thrace.

The results indicate that, if the grid point distribution on the domain boundaries is relatively smooth, then the coordinate lines satisfy with sufficient accuracy the orthogonality condition, within the limits of the mesh resolution. In the case of fields with complicated geometry, the biharmonic approach allows segmentation of the domain, i.e., one may divide the field into simpler geometrical schemes, for example, quadrilaterals and triangles generate the corresponding coordinate systems, and finally patch the solutions of the subdomains to obtain the global coordinate system for the whole field. This procedure has a great deal in common with the generation of finite elements, and can be accomplished with the biharmonic equation approach, since it would require continuity not only of the coordinate lines, but also of their derivatives at the points of patching.

REFERENCES

1. J. F. THOMPSON, Z. U. A. WARSJI, AND C. W. MASTIN, *J. Comput. Phys.* **47** (1982), 1–108.
2. J. F. THOMPSON, F. C. THAMES, AND C. W. MASTIN, *J. Comput. Phys.* **24** (1977), 274–302.
3. S. NAKAMURA, in “Numerical Grid Generation, Proceedings, Symposium on Numerical Generation of Curvilinear Coordinate Systems, Nashville, Tennessee, April 1982” (J. Thompson, Ed.), Elsevier, New York.
4. R. L. SORENSON AND J. L. STEGER, Grid generation in three dimensions by Poisson equations with control of cell size and skewness at boundary surfaces, in “Advances in Grid Generation, ASME Fluids Engineering Conference, Houston, 1983.”
5. M. M. GUPTA AND R. P. MAHONAR, *J. Comput. Phys.* **33** (1979), 236–248.
6. J. B. BELL, G. R. SHUBIN, AND A. B. STEPHENS, *J. Comput. Phys.* **47** (1982), 463–472.
7. G. R. SHUBIN, A. B. STEPHENS, AND J. B. BELL, in “Numerical Grid Generation, Proceedings, Symposium on Numerical Generation of Curvilinear Coordinate Systems, Nashville, Tennessee, April 1982” (J. Thompson, Ed.), Elsevier, New York.
8. J. W. MCLAURIN, *SIAM J. Numer. Anal.* **11** (1974), 14–33.
9. L. W. EHRLICH AND M. M. GUPTA, *SIAM J. Numer. Anal.* **12** (1975), 773–790.